

## L200 Series Inverter Quick Reference Guide

---

- Single-phase Input      200V Class
- Three-phase Input      200V Class
- Three-phase Input      400V Class



Hitachi Industrial Equipment Systems Co., Ltd.

Manual No. NB6601XA • April 2004





**Caution:** Be sure to read the L200 Inverter Manual and follow its Cautions and Warnings for the initial product installation. This Quick Reference Guide is intended for reference use by experienced users in servicing existing installations.

## Power Circuit Terminals

**Inverter models L200-002NFEF/NFU, -004NFEF/NFU, -005NFEF**

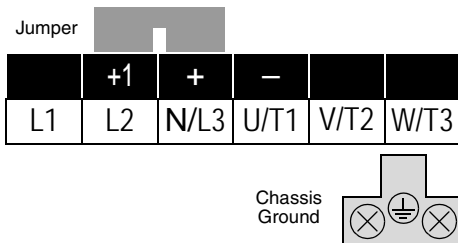

**Inverter models L200-007NFEF/NFU to -022NFEF/NFU, -037LFU, -004HFEF/HFU to -040HFEF/HFU**

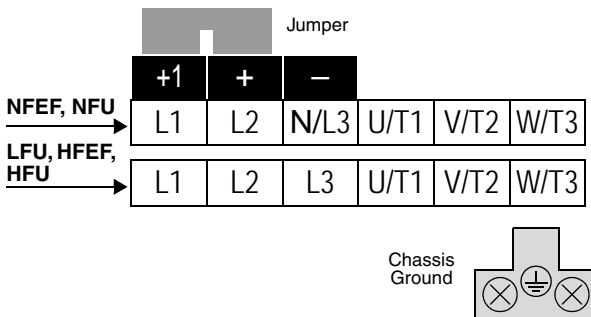

**Inverter models -055LFU, -075LFU, -055HFEF/HFU, -075HFEF/HFU**

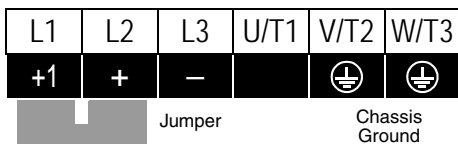

## Control Circuit Terminals

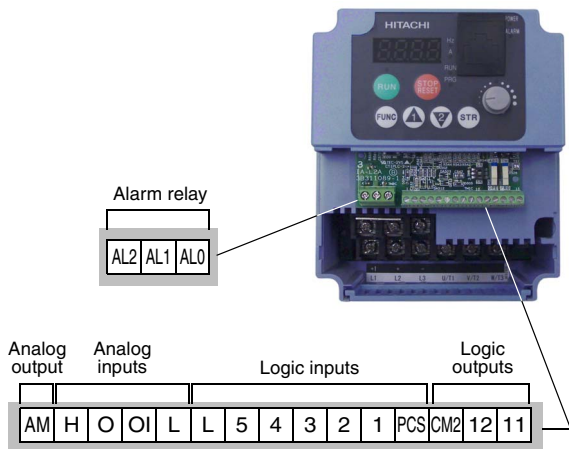

Terminal Name	Description	Ratings and Notes
PCS	+24V for logic inputs	24VDC supply, 30 mA max. (Notes: Do not use for network power Do not short to terminal L)
1, 2, 3, 4, 5	Intelligent (programmable) discrete logic inputs	27VDC max. (use P24 or an external supply referenced to terminal L), 4.7kΩ input impedance
L (right)	GND for logic inputs	Sum of input 1 to 5 currents (Note: Do not ground)
11, 12	Discrete logic outputs	50 mA max. ON current, 27 VDC max. OFF voltage
CM2	GND for logic outputs	100 mA max for sum of terminals 11 and 12 currents
AM	Analog voltage output	0 to 10VDC, 1 mA max., 50% duty cycle
L (left)	GND for analog signals	Sum of OI, O, H, and AM currents (return)

<b>Terminal Name</b>	<b>Description</b>	<b>Ratings and Notes</b>
OI	Analog input, current	4 to 19.6 mA range, 20 mA nominal
O	Analog input, voltage	0 to 9.6 VDC range, 10VDC nominal, 12VDC max., input impedance 10 k $\Omega$
H	+10V analog reference	10VDC nominal, 10 mA max.
AL0	Relay common contact	Contact rating Max resistive load = 250VAC, 2.5A; 30VDC 3A; Max inductive load = 250VAC, 0.2A; 30VDC 0.7A Minimum load = 5VDC 100mA, 100VAC 10mA
AL1	Relay contact, normally closed during RUN	
AL2	Relay contact, normally open during RUN	

# Basic Wiring Diagram

The following wiring diagram shows the power and motor connections for basic operation. The optional signal input wiring supports external Fwd and Rev Run command, and a speed potentiometer.

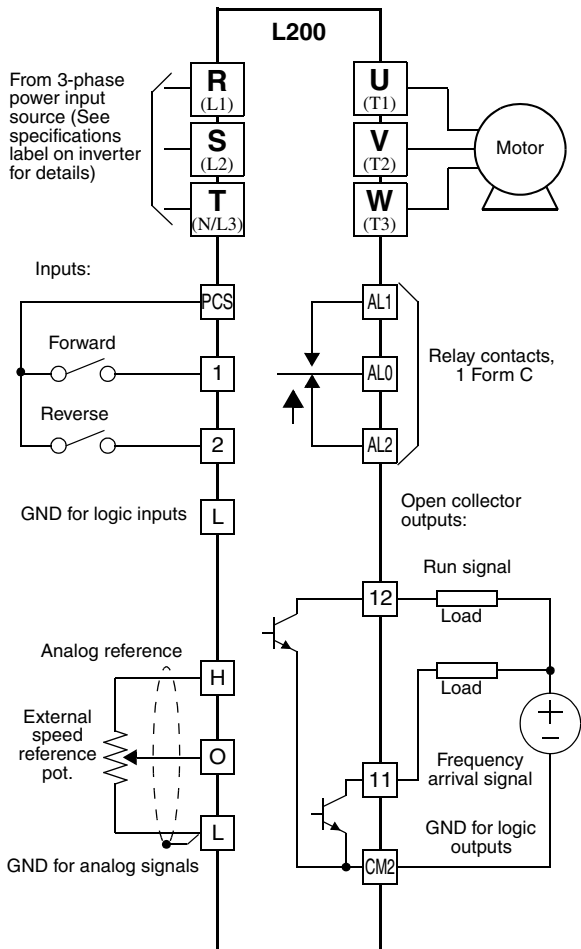

# Inverter Keypad Operation

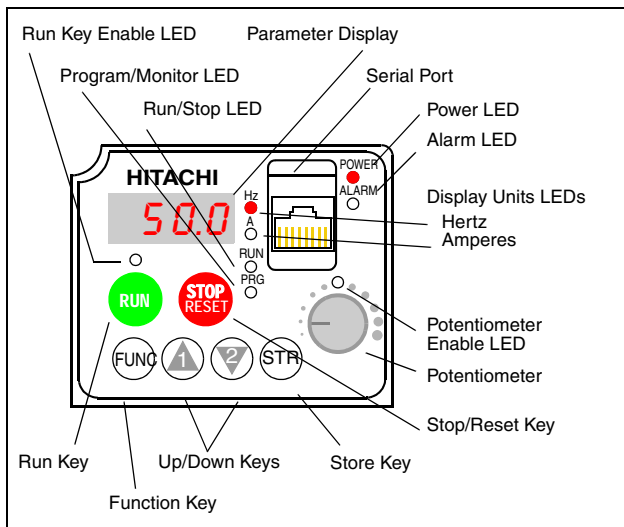

- **Run/Stop LED** – ON when the inverter output is ON and the motor is developing torque, and OFF when the inverter output is OFF (Stop Mode).
- **Program/Monitor LED** – ON when the inverter is ready for parameter editing (Program Mode). It is OFF when the parameter display is monitoring data (Monitor Mode).
- **Run Key Enable LED** – ON when the inverter is ready to respond to the Run key, OFF when the Run key is disabled.
- **Run Key** – Press this key to run the motor (the Run Enable LED must be ON first). Parameter F004, Keypad Run Key Routing, determines whether the Run key generates a Run FWD or Run REV command.
- **Stop/Reset Key** – Press this key to stop the motor when it is running (uses the programmed deceleration rate). This key will also reset an alarm which has tripped.
- **Potentiometer** – Allows an operator to directly set the motor speed when the potentiometer is enabled for output frequency control.
- **Potentiometer Enable LED** – ON when the potentiometer is enabled for value entry.

(continued, next page...)

- **Parameter Display** – A 4-digit, 7-segment display for parameters and function codes.
- **Display Units: Hertz/Amperes** – One of these LEDs will be ON to indicate the units associated with the parameter display.
- **Power LED** – ON when the power input to the inverter is ON.
- **Alarm LED** – ON when the inverter in Trip Mode.
- **Function Key** – This key is used to navigate through the lists of parameters and functions for setting and monitoring parameter values.
- **Up/Down Keys** – Use these keys alternately to move up or down the lists of parameter and functions shown in the display, and to increment/decrement values.
- **Store Key** – When the unit is in Program Mode and the operator has edited a parameter value, press the Store key to write the new value to the EEPROM.

# Keypad Navigation Map

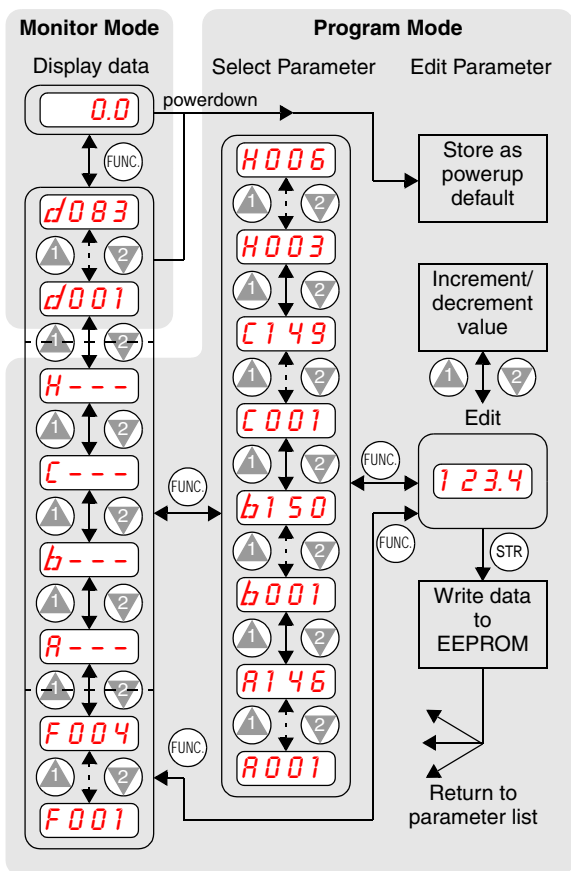

## Powerup Test

The Powerup Test procedure uses minimal parameter settings to run the motor. The procedure describes two alternative methods for commanding the inverter: *via the inverter keypad*, or *via the logic terminals*.

- Check power input and motor output wiring (see page 4 diagram).
- If using logic terminals for testing, verify correct wiring on [PCS], [FW], [H], [O], and [L] (bottom row) per the diagram on page 4.
- Reverse [RV] input wiring (defaults to terminal [2]) is optional.

Step	Description	Via Keypad	Via Logic Terminals
1	Set speed command source setting	A001 = 00 (keypad pot.)	A001 = 01, [H–O–L] input
2	Set Run FW command source	A002 = 02 (Run key)	A002 = 01, [FW] input
3	Set Run REV command source	—	C002 = 01, [RV] input
4	Set motor base freq.	A003 = 60	
5	Set motor poles (2 / 4 / 6 / 8)	H004 = 4 (default), change only if your motor is different	
6	Set keypad display to monitor freq.	Access D001, press Func. key, display will show <b>0.0</b>	
	Perform safety check	Disconnect load from motor	
7		Turn keypad pot. to MIN position	Ensure voltage on [O]—[L] terminals= 0V
8	Run Forward command	Press Run key	Turn ON the [FW] terminal
9	Increase speed	Rotate keypad pot. CW dir.	Increase voltage at [O]
10	Decrease speed	Rotate keypad pot. CCW dir.	Decrease voltage at [O]
11	Stop motor	Press Stop key	Turn OFF the [FW] terminal
12	Run Reverse command (optional)	—	Turn ON the [RV] terminal
13	Stop motor	—	Turn OFF the [RV] terminal

## Error Codes

The L200 series inverters will trip on over-current, over-voltage, and under-voltage to protect the inverter. The motor output turns OFF, allowing the motor to free-run to a stop. Press the Stop/Reset key to reset the inverter and clear the error.



### Basic Error Codes

Error Code	Name	Probable Cause(s)
<b>E01</b>	Over current event while at constant speed	<ul style="list-style-type: none"> <li>• Inverter output was short-circuited</li> <li>• Motor shaft is locked</li> <li>• Load is too heavy</li> <li>• A dual-voltage motor is wired incorrectly</li> </ul> Note: The L200 will over current trip at nominally 200% of rated current
<b>E02</b>	Over current event during deceleration	
<b>E03</b>	Over current event during acceleration	
<b>E04</b>	Over current event for other conditions	<ul style="list-style-type: none"> <li>• DC braking power(A054) set too high</li> <li>• Current transformer / noise error</li> </ul>
<b>E05</b>	Overload protection	<ul style="list-style-type: none"> <li>• Motor overload is detected by the electronic thermal function</li> </ul>
<b>E07</b>	Over voltage protection	<ul style="list-style-type: none"> <li>• DC bus voltage exceeds a threshold, due to regenerative energy from motor</li> </ul>
<b>E08</b>	EEPROM error	<ul style="list-style-type: none"> <li>• Built-in EEPROM memory experienced noise, high temperature, etc.</li> </ul>
<b>E09</b>	Under-voltage error	<ul style="list-style-type: none"> <li>• DC bus voltage decreased enough to cause a control circuit fault</li> </ul>
<b>E11</b> <b>E22</b>	CPU error	<ul style="list-style-type: none"> <li>• Built-in CPU had internal error</li> </ul>
<b>E12</b>	External trip	<ul style="list-style-type: none"> <li>• [EXT] input signal detected</li> </ul>
<b>E13</b>	USP (Unattended Start Protection)	<ul style="list-style-type: none"> <li>• When (USP) was enabled, an error occurred when power was applied while a Run signal was present</li> </ul>
<b>E14</b>	Ground fault	<ul style="list-style-type: none"> <li>• A ground fault was detected between the inverter output and the motor. This feature protects the inverter, and does not protect humans.</li> </ul>
<b>E15</b>	Input over-voltage	<ul style="list-style-type: none"> <li>• Input voltage was higher than specified value, after 60 sec. in Stop Mode</li> </ul>
<b>E21</b>	Inverter thermal trip	<ul style="list-style-type: none"> <li>• Inverter internal temperature is above the threshold</li> </ul>
<b>E30</b>	Driver error	<ul style="list-style-type: none"> <li>• Inverter internal error, electrical noise at CPU-to-drive circuit interface.</li> </ul>

Error Code	Name	Probable Cause(s)
<b>E35</b>	Thermistor	• Thermistor input, [THM] and [L], is over the temp. threshold
<b>E60</b>	Communications error	• The inverter's watchdog timer for the communications network has timed out.
<b>---</b>	Under-voltage (brownout) with output shutoff	• Low input voltage caused the inverter to turn OFF the motor output and try to restart. If unsuccessful, a trip occurs.

## Error Trip Conditions

Use function code D081 to access the error trip conditions for the current error as shown in the table below. Use the Up and Down arrow keys to scroll through the trip condition parameters.

Step	Display
1. Access D081	<b>d081</b>
2. Press Function Key	If no error:  <b>---</b>
	If error exists: <b>EXX</b> (error code)
3. Press Up/Dn key (if error exists)   	Output frequency at trip point: <b>10.0</b> Motor current at trip point: <b>2.5</b> DC bus voltage at trip point: <b>284.0</b> Cumulative Run time house at trip point: <b>15</b> Cumulation power-ON hours at trip point: <b>18</b>

## Restoring Factory Default Settings

Action	Display	Function/Parameter
Press (FUNC.), (1) or (2) as needed.	<i>b---</i>	“B” Group selected
Press (FUNC.).	<i>b001</i>	First “B” Group parameter
Press/hold (1) until...	<i>b085</i>	Country code for initialization selected
Press (FUNC.). If setting is correct, then skip next step.	<i>02</i>	00 = Japan 01 = Europe 02 = USA
To change country code, press (1) or (2) to set; (STR) to store.		
Press (FUNC.).	<i>b085</i>	Country code for initialization selected
Press (2).	<i>b084</i>	Initialization function selected
Press (FUNC.).	<i>00</i>	00 = disable initialization, clear trip history only
Press (1).	<i>01</i>	01 = enable initialization
Press (STR).	<i>b084</i>	Initialization now enabled to restore all defaults
Press/hold (FUNC.), (1), (2), and  keys. Do not release yet.	<i>b084</i>	First part of key sequence
When your country code appears in the display, release all the keys.	<i>EU</i> <i>USA</i> <i>JP</i>	Default parameter country code shown during initialization
Initialization is complete.	<i>d001</i>	Function code for output frequency monitor shown



**Note:** After initializing the inverter, use the Powerup Test on page 8 to get the motor running again.

# Parameter Tables

## “D” Group: Monitoring Functions

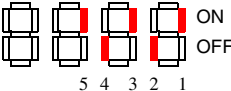
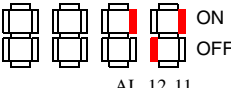
Func. Code	Name / Description	Units
D001	Output frequency monitor	Hz
D002	Output current monitor	A
D003	Rotation direction monitor  Forward      Stop      Reverse <hr style="width: 50%; margin: 0 auto;"/> Direction	—
D004	Process variable (PV), PID feedback monitor	%
D005	Intelligent input terminal status  ON OFF 5 4 3 2 1 <hr style="width: 50%; margin: 0 auto;"/> Terminal Numbers	—
D006	Intelligent output terminal status  ON OFF AL 12 11 <hr style="width: 50%; margin: 0 auto;"/> Terminal Numbers	—
D007	Scaled output frequency monitor (output frequency x B086 scale factor)	User-defined
D013	Output voltage monitor	V
D016	Cumulative operation RUN tim monitor	hours
D017	Cumulative power-on time monitor	hours

## Trip History and Inverter Status

Func. Code	Name / Description	Units
D080	Trip Counter	Hz
D081	Trip monitor 1 (most recent trip n)	—
D082	Trip monitor 2 (trip n-1)	—
D083	Trip monitor 3 (trip n-2)	—

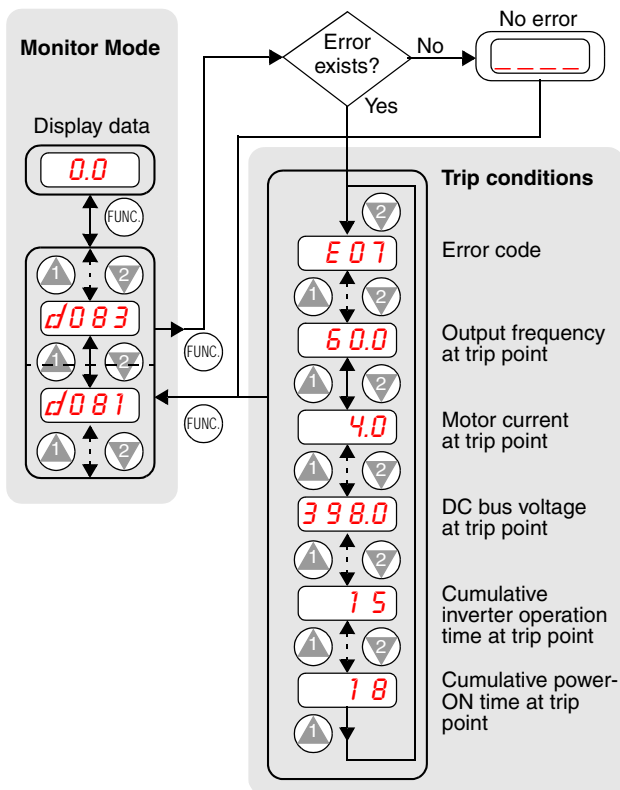

Parameter tables for user-settable functions follow these conventions:

- Some parameters have 2nd motor equivalents, indicated by the x2xx parameter codes in the left-most column.
- Some parameters specify an option code. Where applicable, the options codes will be in a bulleted list in the Name/Description column.
- The default values apply to all models unless otherwise noted for each parameter... –FEF (Europe) / –FU (USA)
- Some parameters cannot be edited during Run Mode, and certain Software Lock settings (B031) can prohibit all edits. If in doubt, place the inverter in Stop Mode or consult the inverter manual for details.

## “F” Group: Main Profile Parameters

Func. Code	Name / Description	Default Value	Set Value
F001	Output frequency setting	0.0	
F002	Acceleration (1) time setting	10.0	
F202	Acceleration (1) time setting, 2nd motor	10.0	
F003	Deceleration (1) time setting	10.0	
F203	Deceleration (1) time setting, 2nd motor	10.0	
F004	Keypad Run key routing • 00 Forward                      • 01 Reverse	00	

## “A” Group: Standard Functions

Func. Code	Name / Description	Default Value –FEF / –FU	Set Value
A001	Frequency source setting • 00 Keypad potentiometer • 01 Control terminal • 02 Function F001 setting • 03 ModBus network input • 10 Calculate function input	01 / 00	
A002	Run command source setting • 01 Input terminal FW or RV (assignable) • 02 Run key on keypad, or digital operator • 03 ModBus network input	01 / 02	

Func. Code	Name / Description	Default Value -FEF / -FU	Set Value
A003/ A203	Base frequency setting	50.0 / 60.0	
A004/ A204	Maximum frequency setting	50.0 / 60.0	
A005	[AT] selection <ul style="list-style-type: none"> <li>• 00 Select between [O] and [OI] at [AT]</li> <li>• 01 [O]+[OI] ([AT] input is ignored)</li> <li>• 02 Select between [O] and keypad pot</li> <li>• 03 Select between [OI] and keypad pot</li> </ul>	00	
A011	Pot./O-L input active range start frequency	0.0	
A012	Pot./O-L input active range end frequency	0.0	
A013	Pot./O-L input active range start voltage	0.	
A014	Pot./O-L input active range end voltage	100.	
A015	Pot./O-L input start frequency enable <ul style="list-style-type: none"> <li>• 00 Use A011 starting value)</li> <li>• 01 Use 0 Hz</li> </ul>	01	
A016	External frequency filter time constant	2. / 8.	
A020/ A220	Multi-speed frequency setting	0	
A021 A022 A023 A024 A025 A026 A027.. ..A035	Multi-speed frequency settings (for both motors)	0.0 / 0.0 0.0 / 0.0 0.0 / 0.0 0.0 / 0.0 0.0 / 0.0 0.0 / 0.0 ..... 0.0 / 0.0	
A038	Jog frequency setting	1.00	
A039	Jog stop mode <ul style="list-style-type: none"> <li>• 00 Free-run stop, jogging disabled during motor run</li> <li>• 01 Controlled deceleration, jogging disabled during motor run</li> <li>• 02 DC braking to stop, jogging disabled during motor run</li> </ul>	00	
A041/ A241	Torque boost select <ul style="list-style-type: none"> <li>• 00 Manual torque boost</li> <li>• 01 Automatic torque boost</li> </ul>	00	
A042/ A242	Manual torque boost value	5.0(A042)/ 0.0 (A242)	
A043/ A243	Manual torque boost frequency adjustment	3.0/(A043) 0.0(A243)	

Func. Code	Name / Description	Default Value -FEF / -FU	Set Value
A044/ A244	V/f characteristic curve selection • 00 V/f constant torque • 01 V/f variable torque	00	
A045	V/f gain setting	100.	
A051	DC braking enable • 00 Disable                      • 01 Enable	00	
A052	DC braking frequency setting	0.5	
A053	DC braking wait time	0.0	
A054	DC braking force during deceleration	0.	
A055	DC braking time for deceleration	0.0	
A056	DC braking / edge or level detection for [DB] input	01	
A061/ A261	Frequency upper limit setting	0.0	
A062/ A262	Frequency lower limit setting	0.0	
A063 A065 A067	Jump (center) frequency setting	0.0	
A064 A066 A068	Jump (hysteresis) frequency width setting	0.5	
A071	PID Enable • 00 PID operation OFF • 01 PID operation ON	00	
A072	PID proportional gain	1.0	
A073	PID integral time constant	1.0	
A074	PID derivative time constant	0.0	
A075	PV scale conversion	1.00	
A076	PV source setting • 00 [OI] terminal (current input) • 01 [O] terminal (voltage input) • 02 ModBus network • 03 Calculate function output	00	
A077	Reverse PID action • 00 PID input = SP - PV • 01 PID input = -(SP - PV)	00	
A078	PID output limit	0.0	

Func. Code	Name / Description	Default Value -FEF / -FU	Set Value
A081	AVR function select • 00 AVR enabled • 01 AVR disabled • 02 AVR enabled except during decel	00	
A082	AVR voltage select	230 / 230 400 / 460	
A092/ A292	Acceleration (2) time setting	15.0	
A093/ A293	Deceleration (2) time setting	15.0	
A094/ A294	Select method to switch to Acc2/Dec2 profile • 00 2CH input from terminal • 01 transition frequency	00	
A095/ A295	Acc1 to Acc2 frequency transition point	0.0	
A096/ A296	Dec1 to Dec2 frequency transition point	0.0	
A097	Acceleration curve selection • 00 Linear • 01 S-curve	00	
A098	Deceleration curve selection • 00 Linear • 01 S-curve	00	
A101	[OI]-[L] input active range start frequency	0.0	
A102	[OI]-[L] input active range end frequency	0.0	
A103	[OI]-[L] input active range start current	0.0	
A104	[OI]-[L] input active range end current	100.	
A105	[OI]-[L] input start frequency enable	01	
A141	A input select for calculate function • 00 Digital operator • 01 Keypad potentiometer • 02 [O] input • 03 [OI] input • 04 Network variable	02	
A142	B input select for calculate function • 00 Digital operator • 01 Keypad potentiometer • 02 [O] input • 03 [OI] input • 04 Network variable	03	
A143	Calculation symbol • 00 ADD (A input + B input) • 01 SUB (A input - B input) • 02 MUL (A input x B input)	00	
A145	ADD frequency	0.0	

Func. Code	Name / Description	Default Value -FEF / -FU	Set Value
A146	ADD direction select <ul style="list-style-type: none"> <li>• 00 Plus (adds A145 value to output frequency)</li> <li>• 01 Minus (subtracts A145 value from output frequency)</li> </ul>	00	

## “B” Group: Fine-tuning Functions

Func. Code	Name / Description	Default Value -FEF / -FU	Set Value
B001	Selection of automatic restart mode <ul style="list-style-type: none"> <li>• 00 Alarm output after trip, automatic restart disabled</li> <li>• 01 Restart at 0Hz</li> <li>• 02 Resume operation after frequency matching</li> <li>• 03 Resume previous freq. after freq. matching, then decelerate to stop and display trip info</li> </ul>	00	
B002	Allowable under-voltage power failure time	1.0	
B003	Retry wait time before motor restart	1.0	
B004	Instantaneous power failure / under-voltage trip alarm enable <ul style="list-style-type: none"> <li>• 00 Disable</li> <li>• 01 Enable</li> </ul>	00	
B005	Number of restarts on power failure / under-voltage trip event <ul style="list-style-type: none"> <li>• 00 Restart 16 times</li> <li>• 01 Always restart</li> </ul>	00	
B012/ B212	Level of electronic thermal setting	Rated current of each inverter	
B013/ B213	Electronic thermal characteristic <ul style="list-style-type: none"> <li>• 00 Reduced torque1</li> <li>• 01 Const. torque</li> <li>• 02 Reduced torque2</li> </ul>	01	
B021	Overload restriction operation mode <ul style="list-style-type: none"> <li>• 00 Disabled</li> <li>• 01 Enabled for accel and constant speed</li> <li>• 02 Enabled for constant speed only</li> </ul>	01	
B022	Overload restriction setting	Rated current x 1.5	

Func. Code	Name / Description	Default Value -FEF / -FU	Set Value
B023	Deceleration rate at overload restriction	1.0 / 30.0	
B031	Software lock mode selection <ul style="list-style-type: none"> <li>• 00 Low-level access, [SFT] blocks edits</li> <li>• 01 Low-level access, [SFT] blocks edits (except F001 and Multi-speed parameters)</li> <li>• 02 No access to edits</li> <li>• 03 No access to edits except F001 and Multi-speed parameters</li> </ul>	01	
B032	Reactive current setting	100.	
B080	[AM] analog signal gain	100.	
B082	Start frequency adjustment	0.5	
B083	Carrier frequency setting	5.0	
B084	Initialization mode (parameters or trip history) <ul style="list-style-type: none"> <li>• 00 Trip history clear</li> <li>• 01 Parameter initialization</li> <li>• 02 Trip history clear and parameter initialization</li> </ul>	00	
B085	Country code for initialization <ul style="list-style-type: none"> <li>• 00 Japan version    • 01 Europe version</li> <li>• 02 USA version</li> </ul>	01 / 02	
B086	Frequency scaling conversion factor	1.0	
B087	STOP key enable <ul style="list-style-type: none"> <li>• 00 Enable            • 01 Disable</li> </ul>	00	
B088	Restart mode after FRS <ul style="list-style-type: none"> <li>• 00 Restart from 0Hz</li> <li>• 01 Restart from frequency detected from actual speed of motor</li> </ul>	00	
B089	Monitor display select for networked inverter, 7 options: <ul style="list-style-type: none"> <li>• 01 Output frequency monitor</li> <li>• 02 Output current monitor</li> <li>• 03 Rotation direction monitor</li> <li>• 04 Process variable (PV), PID feedback monitor</li> <li>• 05 Intelligent input terminal status</li> <li>• 06 Intelligent output terminal status</li> <li>• 07 Scaled output frequency monitor</li> </ul>	01	
B091	Stop mode selection <ul style="list-style-type: none"> <li>• 00 DEC (decelerate and stop)</li> <li>• 01 FRS (free-run to stop)</li> </ul>	00	
B130	Over-voltage LADSTOP enable <ul style="list-style-type: none"> <li>• 00 Disable            • 01 Enable</li> </ul>	00	
B150	Carrier mode <ul style="list-style-type: none"> <li>• 00 Disable            • 01 Enable</li> </ul>	00	

## “C” Group: Intelligent Terminal Functions

Func. Code	Name / Description		Default Value -FEF / -FU	Set Value
C001	Terminal [1] function	Twenty-four option codes available (see page 23)	00	
C002	Terminal [2] function		01	
C003	Terminal [3] function		02 / 16	
C004	Terminal [4] function		03 / 13	
C005	Terminal [5] function		18 / 09	
C011	Terminal [1] active state	<ul style="list-style-type: none"> <li>• 00 Normally open [NO]</li> <li>• 01 Normally closed [NC]</li> </ul>	00	
C012	Terminal [2] active state		00	
C013	Terminal [3] active state		00	
C014	Terminal [4] active state		00 / 01	
C015	Terminal [5] active state		00	
C021	Terminal [11] function	Ten option codes available (see page 24)	01	
C022	Terminal [12] function		00	
C026	Alarm relay terminal function		05	
C028	[AM] signal selection	Two option codes available (see page 24)	00	
C031	Terminal [11] active state	<ul style="list-style-type: none"> <li>• 00 Normally open (NO)</li> <li>• 01 Normally closed (NC)</li> </ul>	00	
C032	Terminal [12] active state		00	
C036	Alarm relay terminal active state		01	
C041	Overload level setting		Rated current of inverter	
C042	Frequency arrival setting for accel		0.0	
C043	Arrival frequency setting for decel		0.0	
C044	PID deviation level setting		3.0	
C052	PID FBV function high limit		100.0	
C053	PID FBV function variable low limit		0.0	
C071	Communication speed selection <ul style="list-style-type: none"> <li>• 04 4800 bps</li> <li>• 05 9600 bps</li> <li>• 06 19200 bps</li> </ul>		06 / 04	
C072	Node allocation		1.	

Func. Code	Name / Description	Default Value -FEF / -FU	Set Value
C074	Communication parity selection • 00 No parity • 01 Even parity • 02 Odd parity	00	
C075	Communication stop bit selection	1	
C076	Communication error select • 00 Trip (error code E60) • 01 Decelerate to stop and trip (error code E60) • 02 Disable • 03 Free run stop (coasting) • 04 Decelerate to a stop	02	
C077	Communication error time-out	0.00	
C078	Communication wait time	0.	
C081	O input span calibration	100.0	
C082	OI input span calibration	100.0	
C085	Thermistor input tuning	100.0	
C086	[AM] terminal offset tuning	0.0	
C091	Debug mode enable • 00 Display                      • 01 No display	00	
C101	Up/Down memory mode selection • 00 Clear last frequency (return to default frequency F001) • 01 Keep last frequency adjusted by UP/DWN	00	
C102	Reset selection • 00 Cancel trip state at input signal ON transition, stops inverter if in Run Mode • 01 Cancel trip state at signal OFF transition, stops inverter if in Run Mode • 02 Cancel trip state at input signal ON transition, no effect if in Run Mode	00	
C141	Input A select for logic output	Nine option codes available (LOG excluded), see page 24	00
C142	Input B select for logic output		01
C143	Logic function select • 00 [LOG] = A AND B • 01 [LOG] = A OR B • 02 [LOG] = A XOR B	00	
C144	Terminal [11] ON delay	0.0	
C145	Terminal [11] OFF delay	0.0	
C146	Terminal [12] ON delay	0.0	

Func. Code	Name / Description	Default Value -FEF / -FU	Set Value
C147	Terminal [12] OFF delay	0.0	
C148	Output relay ON delay	0.0	
C149	Output relay OFF delay	0.0	

## “H” Group: Motor Constants Functions

Func. Code	Name / Description	Default Value -FEF / -FU	Set Value
H003/ H203	Motor capacity	Factory set	
H004/ H204	Motor poles setting <ul style="list-style-type: none"> <li>• 2 poles</li> <li>• 4 poles</li> <li>• 6 poles</li> <li>• 8 poles</li> </ul>	4	
H006/ H206	Motor stabilization constant	100	

## Intelligent Input Terminal Listing

Symbol	Code	Input Terminal Name
FW	00	Forward Run/Stop
RV	01	Reverse Run/Stop
CF1	02	Multi-speed select, Bit 0 (LSB)
CF2	03	Multi-speed select, Bit 1
CF3	04	Multi-speed select, Bit 2
CF4	05	Multi-speed select, Bit 3 (LSB)
JG	06	Jogging
DB	07	External DC braking
SET	08	Set (select) second motor data
2CH	09	2-stage accel and decel
FRS	11	Free-run stop
EXT	12	External trip
USP	13	Unattended start protection
SFT	15	Software lock
AT	16	Analog input voltage/current sel.
RS	18	Reset inverter
PTC	19	PTC thermistor thermal protection
STA	20	Start (3-wire interface)
STP	21	Stop (3-wire interface)
F/R	22	FWD, REV (3-wire interface)
PID	23	PID disable
PIDC	24	PID Reset
UP	27	Remote control Up func.
DWN	28	Remote control Down func.
UDC	29	Remote control data clearing
OPE	31	Operator control
ADD	50	Add frequency enable
F-TM	51	Force Terminal Mode
—	255	Not selected

## Intelligent Output Terminal Listing

Symbol	Code	Input Terminal Name
RUN	00	Run signal
FA1	01	Freq. arrival type 1 – constant speed
FA2	02	Freq. arrival type 2 – over-frequency
OL	03	Overload advance notice signal
OD	04	Output deviation for PID control
AL	05	Alarm signal
Dc	06	Analog input disconnect detect
FBV	07	PID second stage output
NDc	08	Network detection signal
LOG	09	Logic output function

## Analog Input Configuration

The following table shows the parameter settings and [AT] state required to select various analog input sources.

A005	[AT]	External Frequency Command Input
00	OFF	[O]
	ON	[OI]
01	(ignored)	Sum (O + OI)
02	OFF	[O]
	ON	Keypad potentiometer
03	OFF	[OI]
	ON	Keypad potentiometer

## Analog Output Function Listing

The following table shows the functions available for assignment to the analog output terminal via terminal [AM], option set by C028:

Option Code	Function Name	Description	Corresponding Signal Range
00	Analog freq. monitor	Actual motor speed	0 to max. freq. (Hz)
01	Analog current output monitor	Motor current (% of max. rated output current)	0 to 200%